

**17,500-33,000 lb Capacity Diesel
Pneumatic Tire Lift Trucks**

CAT® Lift
Trucks



Relentless Performance

Make short work of big jobs with durable, heavy-duty Cat® lift trucks. Built to last, they feature a rugged 131-horsepower engine, automatic-shift transmission, and powerful air-over-hydraulic brakes to maximize performance and productivity. Hydrostatic steering, conveniently located controls, and a full-floating operator's compartment help to reduce operator fatigue. Easy access to internal system components simplifies maintenance and helps to ensure robust performance for the long run. When the going gets tough, it's tough to beat Cat lift trucks.

Model	Rated Capacity at 24 in Load Center	600 mm Load Center	Power
DP80	17,500 lb	8000 kg	Diesel
DP90	20,000 lb	9000 kg	Diesel
DP100	22,000 lb	10,000 kg	Diesel
DP115	25,000 lb	11,500 kg	Diesel
DP135	30,000 lb	13,500 kg	Diesel
DP150	33,000 lb	15,000 kg	Diesel

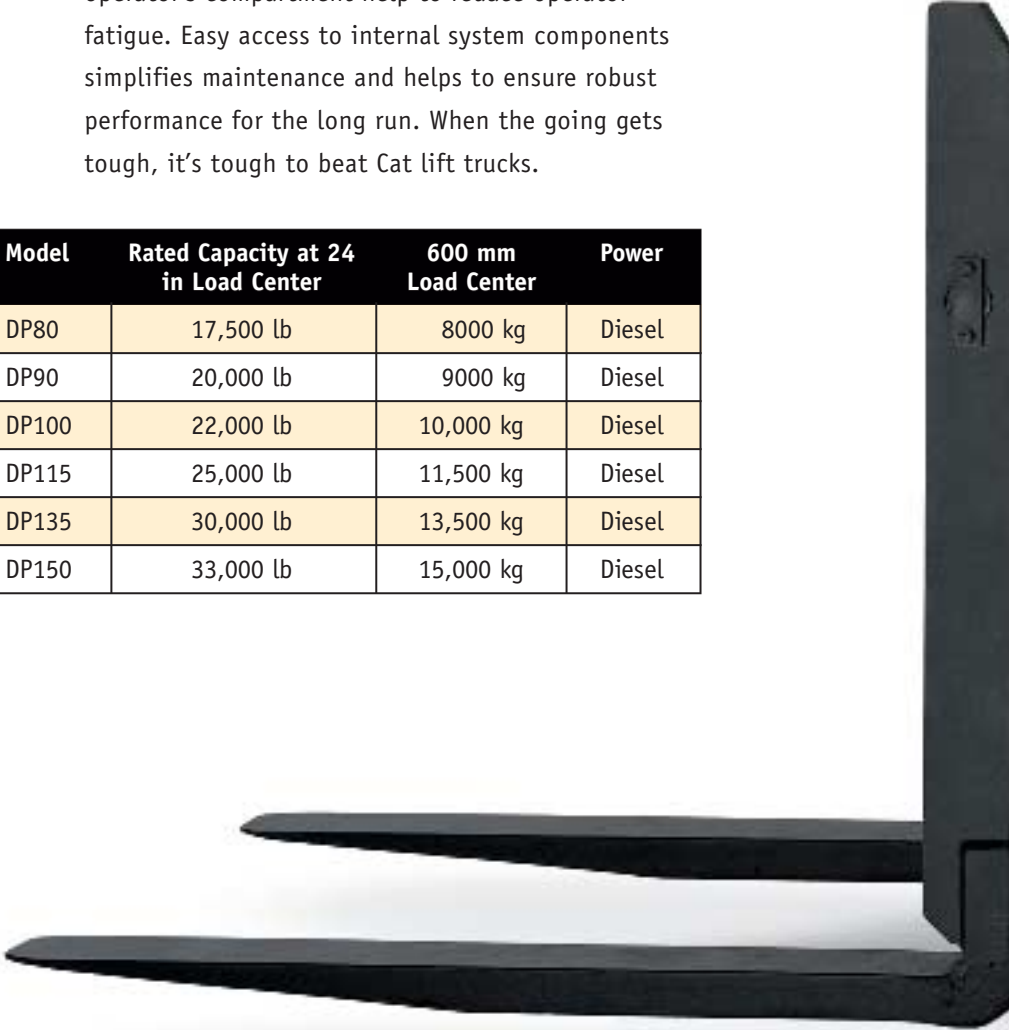



● **6-Cylinder, 131-Horsepower Engine**

With 460 cubic inches of displacement, this in-line, 6-cylinder engine is a great match for demanding applications. It delivers high torque, efficient fuel consumption, and cold-weather starting capabilities to 5°F. Operators will like swift acceleration, low noise, and extended performance.

(Model DP135)



● **Toggle Switch For Versatility**

By simply flipping a switch on the steering console, operators can manually lock the transmission into a lower gear for applications that require top speed control. This allows operators to match the transmission to the job: one-speed, two-speed, or three-speed automatic.

Durable 3-Speed Transmission ●

The automatic transmission offers precision inching and a high-stall torque converter for easy acceleration and exceptional control. An auto-shift feature automatically shifts gears up or down based on travel speed, so the lift truck starts out in first gear, helping to reduce stress on the drive train as well as premature wear on components.





● Full Hydrostatic Steering

Hydrostatic power steering helps reduce operator effort and enhances productivity. The system includes self-aligning kingpins supported by tapered roller bearings and adjustment-free, fixed-length tie rods to help lower maintenance requirements.

A trunnion-mounted steer axle articulates up to 6° for smoother operation and stability. The large-diameter steer cylinder is housed within the steer axle, helping to protect it from debris.

● Non-Asbestos, Air-Over-Hydraulic Brakes

The shoe-type service brakes provide positive braking action with nominal foot pedal pressure—even after the engine shuts down. Cooling fins on the brake drums help dissipate brake heat, and optional Oil Cooled Disc Brakes (OCDB) are available for more severe braking applications. An easy-to-reach, cowl-mounted lever actuates the mechanical parking brake.





(Model DP135)

(Model DP135)



● Good Visibility Masts

Simplex masts tilt 15° forward and 10° back on models DP80 and DP90, and 15° forward and 12° back on DP100 - DP150. With widely spaced channels and twin lift cylinders positioned behind the uprights, these sturdy masts allow for good visibility as well as for fast lift and lowering speeds.



● Grab Bar For Easy Entry And Exit

An easy-to-reach grab handle on the overhead guard facilitates entry and exit of the operator's compartment, situated just three short steps from the ground.

● Comfortable, Full-Floating Operator's Compartment

The operator's compartment is isolated from the frame by rubber mounts that dampen vibration from the engine and transmission.

(Model DP90)



● **Specially Contoured Seat**

The spacious operator's compartment includes a full-suspension, contoured seat with an adjustable-suspension bottom cushion. To help relieve back stress, the seat's molded back lip provides arm support for added leverage when traveling in reverse.

(Model DP90)





(Model DP90)

● **Easy To Access, Service, And Maintain**

Systems under the hood are designed to help make checks as well as routine maintenance quick and easy. The air cleaner, batteries, fuel tank filler, fuel shut-off, and transparent brake fluid reservoir are all easy to reach and inspect. A large-capacity fuel tank helps to allow for more than eight hours of run time, boosting productivity.

● **Easy-To-Open Engine Hood**

The engine hood with gas cylinder assist opens easily for routine maintenance.

(Model DP135)



(Model DP90)



Conveniently Located Controls

Controls are ergonomically designed and strategically positioned to help operators work with ease. On the DP80 and DP90, the tilt steering column facilitates entry and exit of the operator's compartment and accommodates most operator preferences.



At-A-Glance Monitoring

On the instrument panel, universal graphic symbols and a non-glare panel help operators monitor lift truck functions.

Ask For A Demonstration ●

The advantages of the 17,500-33,000 lb capacity diesel pneumatic tire lift trucks become obvious with a demonstration. See strong proof that Cat lift trucks and your Cat lift truck dealer can offer you more productivity-driven benefits for a strong return on your equipment investment. Call for an appointment today.



SPECIFICATIONS

CHARACTERISTICS			DP80		DP90		DP100				
1	Capacity	at rated load center	lb	kg	17,500	8000	20,000	9000	22,000	10,000	
2		at load center – distance	in	mm	24	600	24	600	24	600	
3	Power	diesel, gas, LP gas			diesel		diesel		diesel		
4	Tire type	cushion, pneumatic			pneumatic		pneumatic		pneumatic		
5	Wheels (x = driven)	number front / rear			x4/2		x4/2		x4/2		
DIMENSIONS											
10	Lift	maximum fork height with rated load	in	mm	197	5000	197	5000	217	5500	
11	Lift with standard two-stage mast	maximum fork height	in	mm	148	3700	148	3700	132	3300	
12		free fork height	in	mm	8.7	220	0	0	0	0	
13	Forks	thickness x length x width	in	mm	2.4 x 48 x 7.1	60 x 1220 x 180	2.8 x 48 x 7.1	70 x 1220 x 180	2.8 x 48 x 7.1	70 x 1220 x 180	
		Fork spacing	out-to-out minimum / maximum	in	mm	17.7/65.5	450/1670	31.5/78.5	800/2000	31.5/78.5	800/2000
14	Tilt	forward / backward			15 / 10		15 / 10		15 / 12		
15	Overall dimensions	length to fork face	in	mm	157.5	4000	164	4165	169.1	4295	
16		width	standard dual drive tires	in	mm	94.1	2390	94.1	2390	99	2515
			optional dual drive tires	in	mm	N/A		N/A		N/A	
17		height	with lowered mast	in	mm	123	3125	132.6	3370	123.6	3140
18			seat height	in	mm	60.5	1535	60.5	1535	68.7	1745
19			to top of overhead guard	in	mm	101	2565	101	2565	111.6	2835
20	with extended mast		in	mm	197.8	5025	204.2	5190	188.6	4790	
21	Minimum outside turning radius	in	mm	147.2	3740	151	3835	157.5	4000		
22	Load moment constant	in	mm	26.6	675	29.7	755	29.7	755		
23	Minimum aisle – 90° stack – zero clearance w/out load	in	mm	173.8	4415	180.7	4590	187.2	4755		
PERFORMANCE											
40	Speeds	travel speed loaded / empty	mph	km/h	17.7/20.8	28.5/33.5	16.8/20.5	27/33	15.2/19.6	24.5/31.5	
41		lift speed loaded / empty	fpm	m/s	98/104	.50/.53	81/85	.41/.43	67/71	.34/.36	
42		lowering speed loaded / empty	fpm	m/s	98/98	.50/.50	78/78	.40/.40	88/98	.45/.50	
43	Drawbar pull	loaded at 1 mph (1.6 km)	lb	N	16,015	71,242	15,835	70,426	17,000	75,617	
		loaded maximum	lb	N	22,440	99,821	22,260	99,005	24,180	93,586	
44	Gradeability	loaded at 1 mph (1.6 km)		%	40		34		29		
		maximum loaded / empty			%	61 / 29		51 / 29		50 / 35	
WEIGHT											
50	Empty	lb	kg	25,215	11,435	29,060	13,180	31,860	14,450		
51	Axle load	with rated load front / rear	lb	kg	38,430 / 4510	17,430 / 2005	43,990 / 5070	19,900 / 2280	48,320 / 5540	21,920 / 2530	
		without load front / rear	lb	kg	12,080 / 13,130	5480 / 5955	13,630 / 15,430	6180 / 7000	15,630 / 16,230	7090 / 7360	
CHASSIS											
60	Tire size	front, standard dual drive tires	in		9.00 x 20-12PR		9.00 x 20-14PR		10.00 x 20-14PR		
		front, optional dual drive tires	in		NA		NA		NA		
61		rear	in		9.00 x 20-12PR		9.00 x 20-14PR		10.00 x 20-14PR		
62	Wheelbase	in	mm	101.6	2580	101.6	2580	110.2	2800		
63	Tread width	front, standard dual drive tires	in	mm	71.7	1820	71.7	1820	74.8	1900	
		front, optional dual drive tires	in	mm	NA		NA		NA		
64		rear tires	in	mm	68.9	1750	68.9	1750	76	1930	
65	Ground clearance	at lowest point @ mast	in	mm	8.7	220	8.3	210	8.7	220	
66		at center of wheelbase	in	mm	11	280	11	280	13.4	340	
67	Brakes	service			air over hydraulic-foot		air over hydraulic-foot		air over hydraulic-foot		
68		parking			mechanical-hand		mechanical-hand		mechanical-hand		
POWER TRAIN											
80	Engine	manufacturer and model			Mitsubishi 6D16		Mitsubishi 6D16		Mitsubishi 6D16		
81		continuous output S.A.E. gross	HP	kW	131	98	131	98	131	98	
			at r.p.m.			2200		2200		2200	
82		maximum torque S.A.E. gross	lb-ft	kg-m	347	48	347	48	347	48	
			at r.p.m.			1400		1400		1400	
83	cylinder / displacement	cu	in	cm ³	6 / 460	6 / 7545	6 / 460	6 / 7545	6 / 460	6 / 7545	
84	Transmission	type			automatic powershift		automatic powershift		automatic powershift		
85		number of speeds forward / reverse			3 / 3		3 / 3		3 / 3		
86	Relief pressure	for attachments	psi	bar	2610	180	2610	180	2465	170	
87	Noise level	mean value at operator's ear Leq		dB(A)	89.5		89.5		89.5		

NOTE: These specifications assume the use of drive axles, tires and tilt angles specified. Any modification to specifications, or any other combination of specifications made after the shipment of the truck, requires prior written approval from Mitsubishi Caterpillar Forklift America Inc. ("MCFA"). (See ASME B56.1 Part II 4.2.) Also be advised that overall operating visibility may be affected by the mast configuration and mast options of your truck. Therefore, you may need to add ancillary [auxiliary] devices or modify your operating practices. Consult your dealer for further information.

DP115		DP135		DP150	
25,000	11,500	30,000	13,500	33,000	15,000
24	600	24	600	24	600
diesel		diesel		diesel	
pneumatic		pneumatic		pneumatic	
x4/2		x4/2		x4/2	
217	5500	217	5500	217	5500
132	3300	133	3300	133	3300
0	0	0	0	0	0
3.0 x 48 x 7.1	75 x 1220 x 180	3.5 x 48 x 7.1	90 x 1220 x 180	3.5 x 48 x 7.1	90 x 1220 x 180
31.5/78.5	800/2000	31.5/78.5	800/2000	41.5/89.0	1055/2260
15 / 12		15 / 12		15 / 12	
172	4370	178.3	4530	190.2	4830
99	2515	102.4	2600	102.4	2600
N/A		N/A		N/A	
123.6	3140	137.2	3485	137.2	3485
68.7	1745	70.5	1790	70.5	1790
111.6	2835	113.2	2875	113.2	2875
188.6	4790	205.9	5230	205.9	5230
159.8	4060	163.8	4160	179.1	4550
29.7	755	31.3	795	31.3	795
189.5	4815	195.1	4955	210.4	5345
15.2 / 19.6	24.5/31.5	13.7 / 20.5	22.0/33.0	12.8/20.5	20.5/33.0
67 / 71	.34/.36	57 / 61	.29/.31	55 / 61	.28/.31
88 / 98	.45/.50	75 / 82	.38/.42	75 / 82	.38/.42
16,795	74,696	15,585	69,332	15,550	69,165
23,910	106,351	21,660	96,339	21,715	96,594
26		21		19	
44 / 32		33 / 30		31 / 32	
33,800	15,330	38,190	17,320	39,160	17,760
52,760 / 6040	24,000 / 2830	60,990 / 7200	27,610 / 3210	65,320 / 6840	29,660 / 3100
15,320 / 18,480	6950 / 8380	16,450 / 21,740	7460 / 9860	17,510 / 21,650	7940 / 9820
10.00 x 20 -16PR		12.00 x 20 -18PR		12.00 x 20 -18PR	
N/A		N/A		N/A	
10.00 x 20 -16PR		12.00 x 20 -18PR		12.00 x 20 -18PR	
110.2	2800	110.2	2800	122	3100
74.8	1900	75	1905	75	1905
N/A		N/A		N/A	
76	1930	74.4	1890	74.4	1890
8.7	220	10.2	260	10.2	260
13.4	340	14.9	380	14.9	380
air over hydraulic-foot		air over hydraulic-foot		air over hydraulic-foot	
mechanical-hand		mechanical-hand		mechanical-hand	
Mitsubishi 6D16		Mitsubishi 6D16		Mitsubishi 6D16	
131	98	131	98	131	98
2200		2200		2200	
347	48	347	48	347	48
1400		1400		1400	
6 / 460	6 / 7545	6 / 460	6 / 7545	6 / 460	6 / 7545
automatic powershift		automatic powershift		automatic powershift	
3 / 3		3 / 3		3 / 3	
2465	170	2465	170	2465	170
89.5		89.5		89.5	

SAFETY STANDARDS

These trucks meet American Society of Mechanical Engineers (ASME) B56.1, part III Safety Standards for powered industrial trucks. UL-Classified by Underwriters Laboratories, Inc., as to fire and electric shock hazard only.

Type D Industrial Trucks. Users should be aware of, and adhere to, applicable codes and regulations regarding operator training, use, operation and maintenance of powered industrial trucks, including:

- ASME B56.1, part II.
- NFPA 505, fire safety standard for powered industrial trucks - type designations, areas of use, maintenance and operation.
- Occupational Safety and Health Administration (OSHA) regulations that may apply.

Specifications, equipment, technical data, photos and illustrations based on information at time of printing and subject to change without notice. Some products may be shown with optional equipment.

Call-out numbers shown in diagram correspond to the first column of the specifications chart.

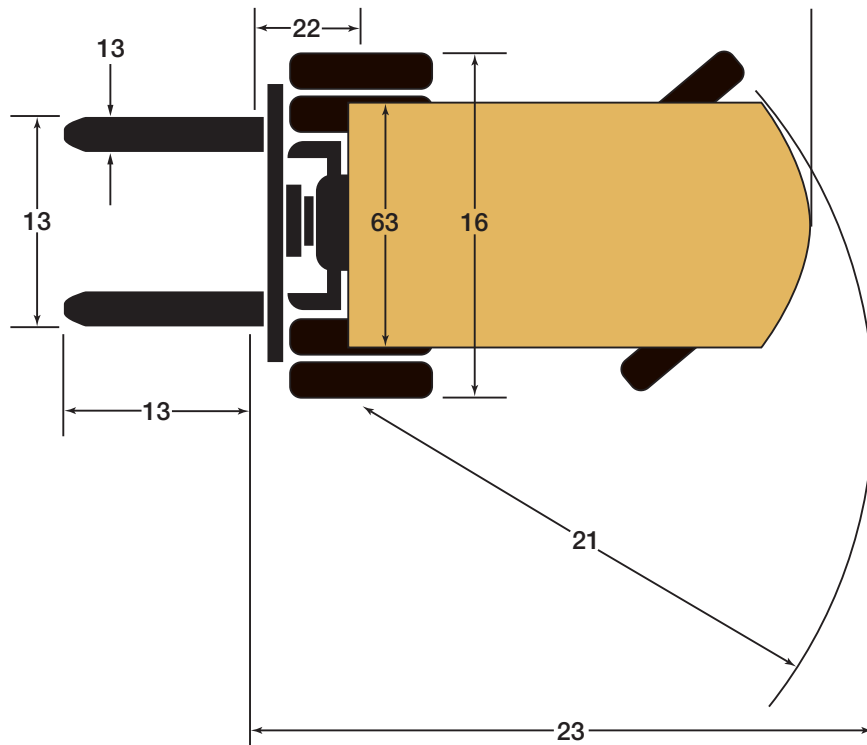
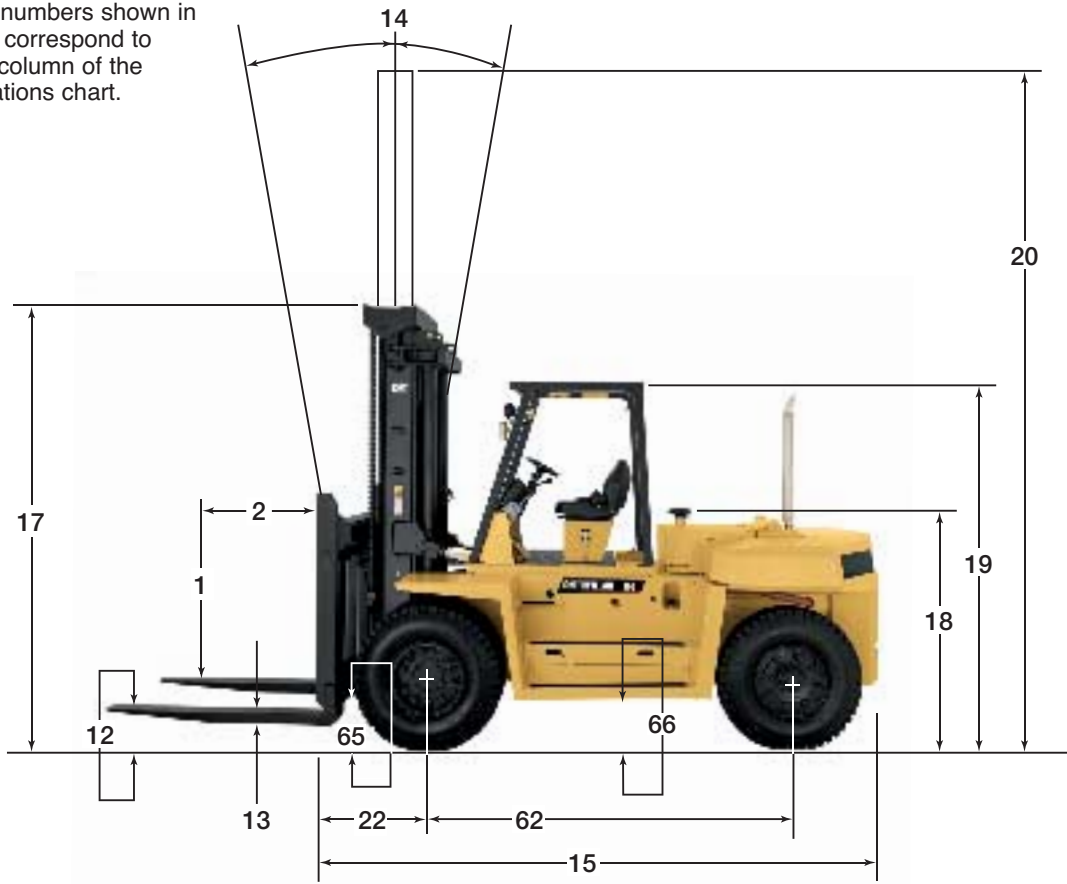



Durability And Support

Cat lift truck dealers put customer needs first, with the most comprehensive customer support programs in the industry.

Unlimited Hours Warranty covers parts and labor for one year, regardless of service hours.

Parts Fast or Parts Free Guarantee ensures next-business-day delivery of parts for all brands of lift trucks or they are free, including freight.

Free Loaner Service Guarantee provides a lift truck until the repair is done if your lift truck is not repaired right the first time and within the quoted time.

Contact your Cat lift truck dealer for complete terms and conditions of these guarantees.



Cat Lift Trucks offers an extensive range of products and services. Your Cat lift truck dealer can provide options and additional visual and audible warning devices geared toward your specific applications and requirements. Operator training programs are also available to boost productivity and to help reduce the potential for product damage and personal injury.

Your Cat lift truck dealer can also provide a variety of financing and leasing options to suit the needs of your business.